

LDN-IS / LDNA-IS series switch boxes

Intrinsically Safe Ex ia

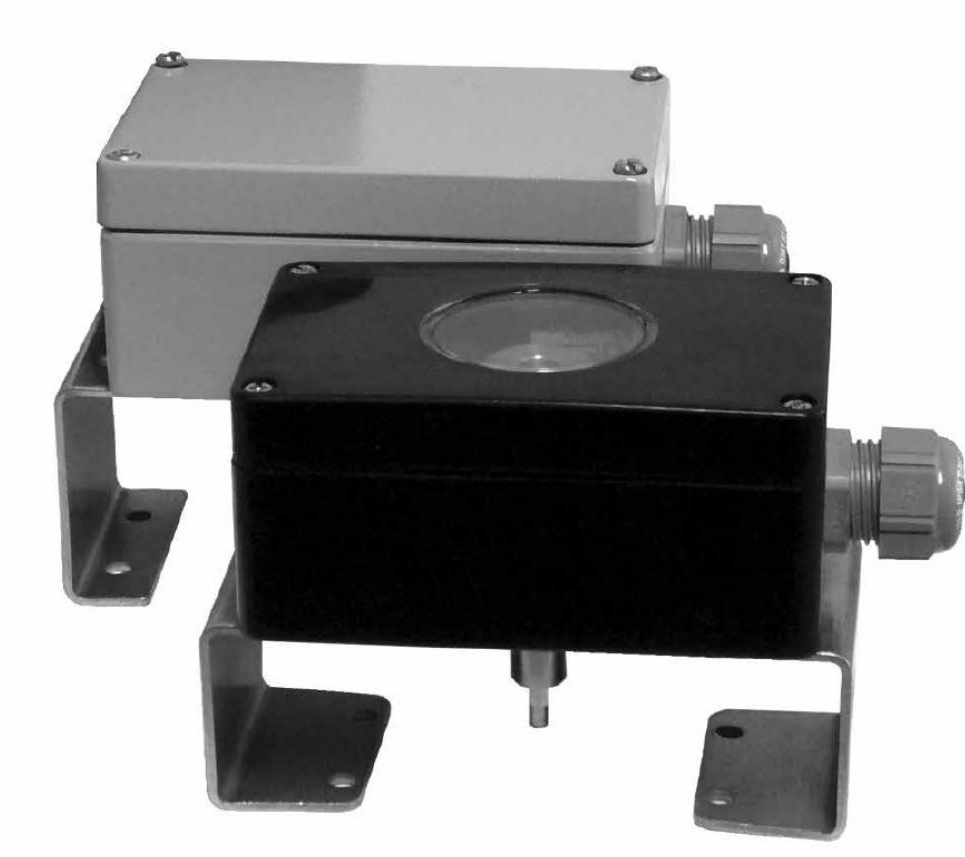

INSTALLATION AND OPERATION INSTRUCTIONS

LDN (A)-IS

Please read carefully this Installation and Operation Instruction. If you have any questions, please do not hesitate to contact us.

1.0 Intended use

The EL-O-MATIC ATEX LDN / LDNA series intrinsically safe switch boxes are group II category 1 or 2 equipment and intended for use in areas in where explosive atmospheres caused by mixtures of air and gases, vapors, mists or by air/dusts are likely to occur. Therefore, it may be used in classified zones 0, 1 and 2 (gases) and zones 20, 21 and 22 (dust). Before installation ensure that the intrinsically safe rating, as marked on the switch box label, is compatible with the application.

2.0 Safety instructions

- 2.1 Assembly, disassembly and maintenance is only allowed at the switch box when, at the time of the activity, there is not an explosive mixture.
- 2.2 These instructions are applicable only for work on the switch box itself.
- 2.3 These instructions are not applicable for assembly or disassembly of:
 - 2.3.1 the valve
 - 2.3.2 the actuator onto a valve
 - 2.3.3 accessories, like for example solenoid valves
- 2.4 Installation, adjustment, putting into service, use, assembly, disassembly and maintenance of the pneumatic actuator is strictly reserved to qualified personnel.
- 2.5 When used in a potentially explosive atmosphere, requiring the use of the apparatus of equipment category 1D or 2D, cable entry devices shall be used that are suitable for the application, with a degree of ingress protection of \geq IP5x according to the latest version of EN 60079-0, be suitable for a temperature range from -20°C to 85°C and correctly installed.
- 2.6 To avoid voltage and current addition, the separation and wiring of the intrinsically safe circuits shall be in accordance with EN 60079-14.

3.0 Special conditions for safe use

When the switch box type LDNA is used in a potentially explosive atmosphere, requiring the use of apparatus of equipment category 1G, the switch box shall be installed so, that even in the event of rare incidents, ignition sources due to impact and friction sparks are excluded. When the switch box type LDNA is used in a potentially explosive atmosphere, requiring the use of equipment category 1D or 2D apparatus, electrostatic charges on the coated parts of the switch box need to be avoided.

Electrostatic charges of the labels shall be avoided.

The limit values for the ambient temperature range depending on the temperature class, connection types and switching type can be found in the tables in this operating instructions, page 7 or, if applicable, page 9.

INSTALLATION AND OPERATION INSTRUCTIONS

LDN (A)-IS

4.0 Installation instructions

- 4.1 Mount the switch box onto the actuator using a mounting kit prepared in accordance with VDI/VDE 3845 (NAMUR)
- 4.2 Make the correct electrical connections according the appropriate control drawing:

drawing	page of this instruction	description
C0349-01	6	Proximity switches (II 1 & 2 GD)
C0623-01	8	Proximity switches (II 1 & 2 GD)

- 4.3 When assembling IS8 and IS9 switch boxes, the cable entry device shall prevent that the cable slips for more than 6mm to avoid tensile stress on the clamps / terminal.
- 4.4 The clamping nut of the cable gland must be tightened to 4.5 Nm for the cable glands regularly supplied by EL-O-MATIC. Always observe the operating instructions of the manufacturer of the cable gland used.
- 4.5 Do not exceed the specification limitations as indicated on the appropriate control drawing.
- 4.6 After installation, please check that the cover is firmly closed.

5.0 Contact adjustment

Switch contact points are factory set to operate 5° before each end position. If required at another position, please carry out the following:

- Remove the cover.
- Set the actuator to the position where indication is required (for spring return actuators, the connection of an air supply will be required).
- Choose the required cam.
- Slacken the fixing screw and rotate the cam until the switch contact is made. To check, please use a circuit tester across the appropriate terminals
- Tighten the cam fixing screw.
- Check again if the correct contact position has been achieved. Adjust further, as necessary, according steps a) – f).
- Put the cover back in place.

Switch boxes IS8 and IS9 have fixed switch points which need no adjustment in the field.

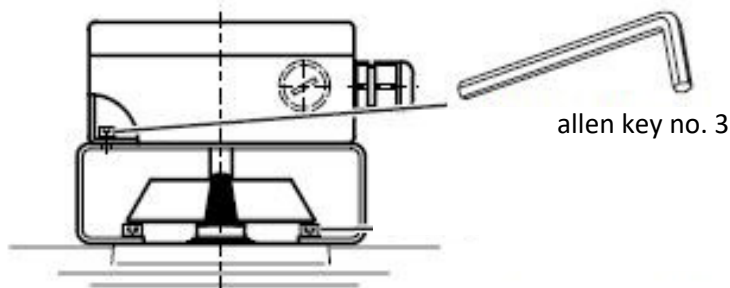

Figure 1 shows the attachment of the switch box on top of VDI/VDE bracket.

INSTALLATION AND OPERATION INSTRUCTIONS

LDN (A)-IS

Figure 2: Cam / vane options for IS1, IS2 and IS10

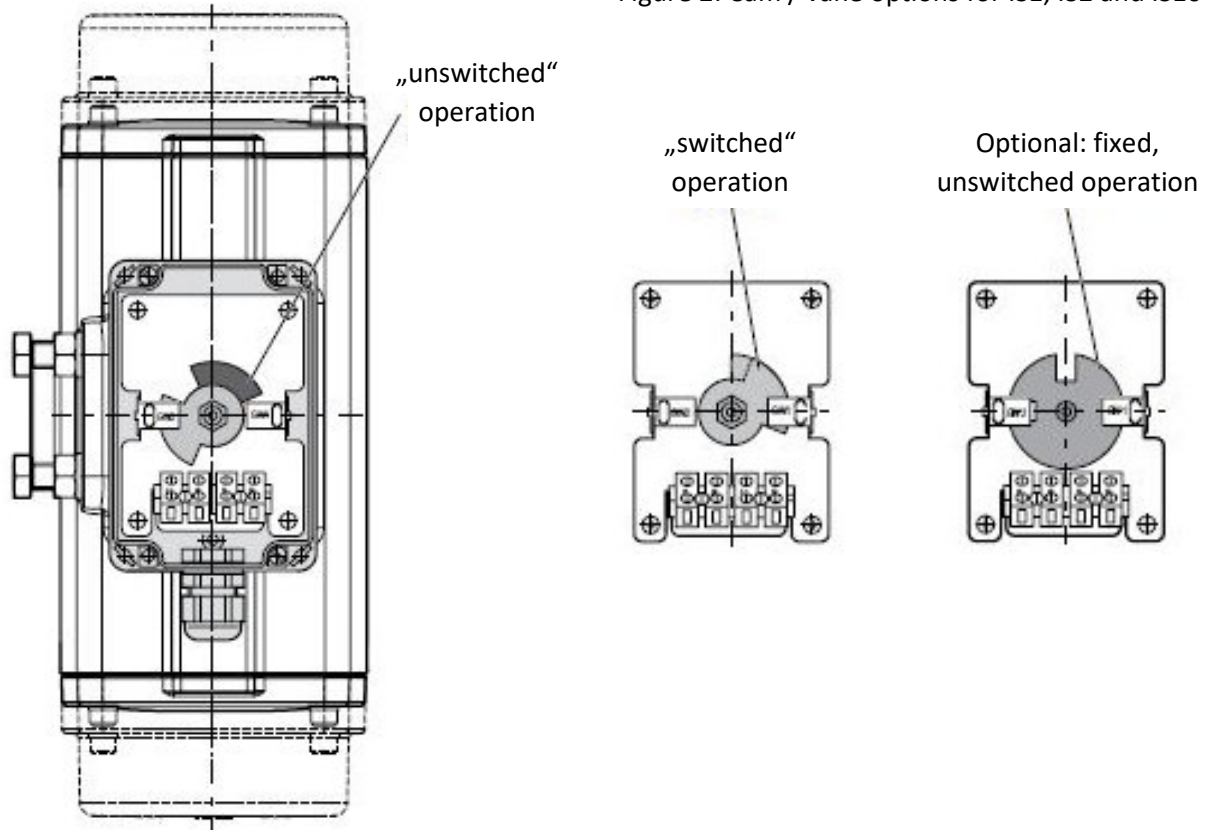

Figure 3: Switch operation vane for IS4

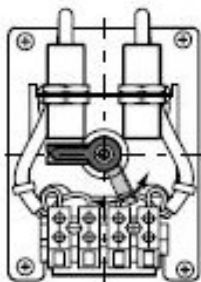
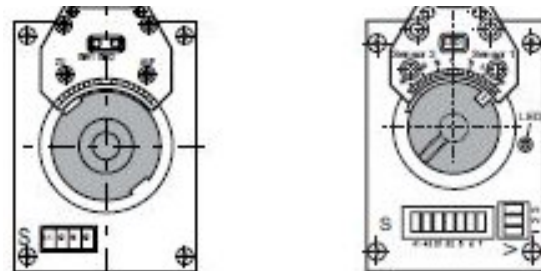

Figure 4: IS8 and IS9 have fixed switch points which need no adjustment



INSTALLATION AND OPERATION INSTRUCTIONS

LDN (A)-IS

Labelling overview LDN switch boxes

LDN Design	Marking	Zone (Gas)
IS1	II 1G Ex ia IIC T6...T4 Ga	0, 1, 2
IS2	II 1G Ex ia IIC T6...T4 Ga	0, 1, 2
IS4	II 1G Ex ia IIC T6...T4 Ga	0, 1, 2
IS8	II 1G Ex ia IIC T6...T4 Ga	0, 1, 2
IS9	II 1G Ex ia IIC T6...T4 Ga	0, 1, 2
IS10	II 1G Ex ia IIC T6...T4 Ga	0, 1, 2

Labelling overview LDNA switch boxes

LDNA Design	Marking	Zone (Gas and Dust)
IS1	II 1G Ex ia IIC T6...T4 Ga	0, 1, 2
	II 1D Ex ia IIIC T ₂₀₀ T41°C...T80°C Da	20, 21, 22
IS2	II 1G Ex ia IIC T6...T4 Ga	0, 1, 2
	II 1D Ex ia IIIC T ₂₀₀ T41°C...T80°C Da	20, 21, 22
IS4	II 1G Ex ia IIC T6...T4 Ga	0, 1, 2
	II 1D Ex ia IIIC T ₂₀₀ T41°C...T80°C Da	20, 21, 22
IS8	II 1G Ex ia IIC T6...T4 Ga	0, 1, 2
	II 1D Ex ia IIIC T ₂₀₀ T41°C...T80°C Da	20, 21, 22
IS9	II 1G Ex ia IIC T6...T4 Ga	0, 1, 2
	II 1D Ex ia IIIC T ₂₀₀ T41°C...T80°C Da	20, 21, 22
IS10	II 1G Ex ia IIC T6...T4 Ga	0, 1, 2
	II 1D Ex ia IIIC T ₂₀₀ T41°C...T80°C Da	20, 21, 22

INSTALLATION AND OPERATION INSTRUCTIONS

LDN (A)-IS

Control drawing: LDN(A) / 1 & 2 GD: C0349-01, sheet 1 of 2

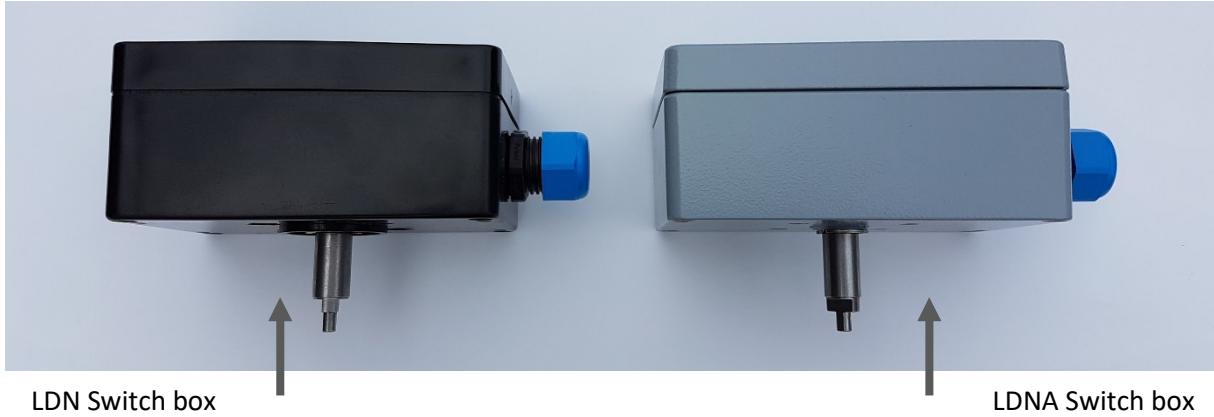

electrical values:

	connection type			
	Type 1	Type 2	Type 3	Type 4
Ui	16 V	16 V	16 V	16 V
Ii	25 mA	25 mA	52 mA	76 mA
Pi	34 mW	64 mW	169 mW	242 mW

	switch type Ci and Li values	
	Ci (nF)	Li (µH)
SJ3,5-SN	30	100
SJ3,5-N	50	250
NJ2-11-N-G	30	50
SC3,5-G-N0	150	150

Wiring diagram

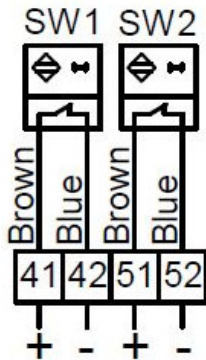

Marking on the LDN switch box

EL-O-MATIC GmbH, Siemensring 112, 47877 Willich, Germany

TYPE:

SERIAL NO.:

YEAR: DEKRA 18ATEX0079X

II 1G Ex ia IIC T6...T4 Ga

Marking on the LDNA switch box

EL-O-MATIC GmbH, Siemensring 112, 47877 Willich, Germany

TYPE:

SERIAL NO.:

YEAR: DEKRA 18ATEX0079X

II 1G Ex ia IIC T6...T4 Ga II 1D Ex ia IIIC T00 T41°C...80°C Da

INSTALLATION AND OPERATION INSTRUCTIONS

LDN (A)-IS

Control drawing: LDN(A) / 1 & 2 GD: C0349-01, sheet 2 of 2

Temperature ranges (all values in in °C)

for category 1G or 2G	connection type 1			connection type 2			connection type 3			connection type 4		
type of sensor	T4	T5	T6	T4	T5	T6	T4	T5	T6	T4	T5	T6
SJ3,5-SN	80	80	73	80	80	66	80	60	45	74	45	30
SJ3,5-N	80	80	73	80	80	66	80	60	45	74	45	30
NJ2-11-N-G	80	80	76	80	80	73	80	77	62	63	63	54
SC3,5-G-N0	80	80	73	80	80	66	80	60	45	74	45	30

The maximum ambient temperature T in relation to the type of connection, temperature class and type of switch for category 1G or 2G is shown in the above table. For box type LDN the values of the maximum ambient temperature are to be reduced by 10°C.

for category 1D or 2D	connection type 1			connection type 2			connection type 3			connection type 4		
	ambient temperature Ta											
type of sensor	surface temperature T											
	40	60	79	40	60	78	40	60	74	40	60	72
SJ3,5-SN	41	61	80	42	62	80	46	66	80	48	68	80
SJ3,5-N	41	61	80	42	62	80	46	66	80	48	68	80
NJ2-11-N-G	41	61	80	42	62	80	46	66	80	48	68	80
SC3,5-G-N0	41	61	80	42	62	80	46	66	80	48	68	80

The maximum surface temperature T in relation to the switch type, the connection type and the maximum ambient temperature for the assembly type LDNA for category 1D or 2D is listed in above table and based on a layer of dust thickness of maximum 200mm.

Attention: No change in part or vendor allowed without prior approval of DEKRA

INSTALLATION AND OPERATION INSTRUCTIONS

LDN (A)-IS

Control drawing: LDN(A) / 1 & 2 GD PL2, PL3: C0623-01, sheet 1 of 2

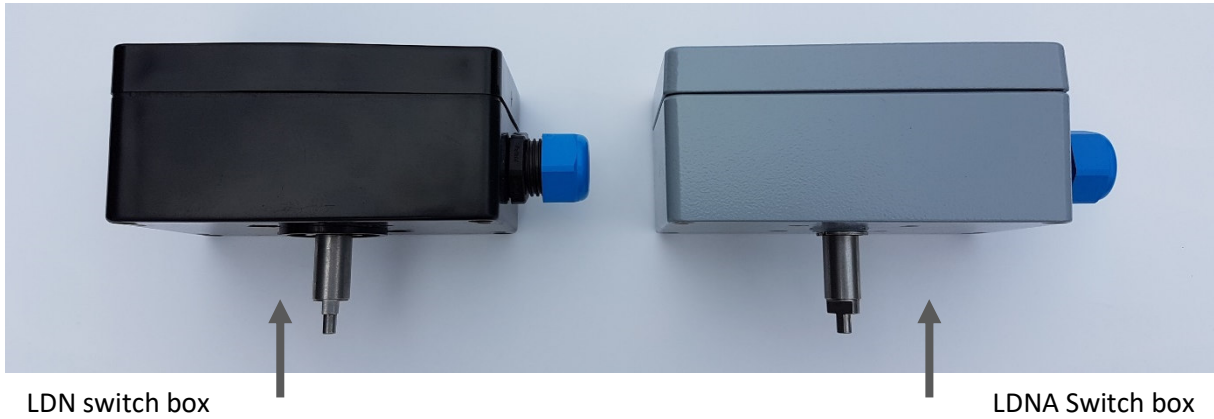

electrical values:

	connection type		
	Type 1b	Type 2b	Type 3b
Ui	15 V	15 V	15 V
Ii	25 mA	25 mA	52 mA
Pi	34 mW	64 mW	169 mW

	switch type Ci and Li values	
	Ci (nF)	Li (µH)
PL2-F25-N4-K	100	100
PL3-F25-N4-K	100	100

Wiring diagram 1, PL2-F25-N4-K

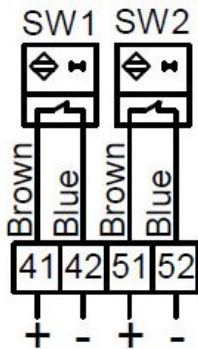

Wiring diagram 2, PL3-F25-N4-K

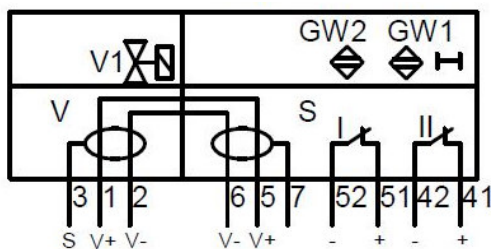

Marking on the LDN switch box

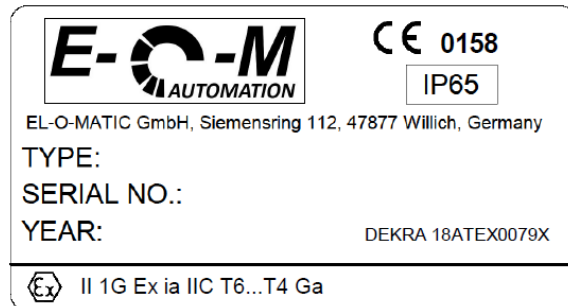

Marking on the LDNA switch box



INSTALLATION AND OPERATION INSTRUCTIONS

LDN (A)-IS

Control drawing: LDN(A) / 1 & 2 GD PL2, PL3: C0623-01, sheet 2 of 2

Temperature ranges (all values in in °C)

for category 2G	connection type 1b			connection type 2b			connection type 3b			Wiring diagram no:
type of sensor	T4	T5	T6	T4	T5	T6	T4	T5	T6	
PL2-F25-N4-K	80	75	60	80	75	60	80	75	60	1
PL3-F25-N4-K	80	75	60	80	75	60	80	75	60	2
for category 1G										
PL2-F25-N4-K	80	55	45	80	55	45	80	55	45	1
PL3-F25-N4-K	80	55	45	80	55	45	80	55	45	2

The maximum ambient temperature T in relation to the type of connection, temperature class and type of switch for category 1G or 2G is shown in the above table. For box type LDN the values of the maximum ambient temperature are to be reduced by 10°C.

for category 1D or 2D	connection type 1b			connection type 2b			connection type 3b			Wiring diagram no:
	ambient temperature Ta									
	40	60	79	40	60	78	40	60	74	
type of sensor	surface temperature T									
PL2-F25-N4-K	41	61	80	42	62	80	46	66	80	1
PL3-F25-N4-K	41	61	80	42	62	80	46	66	80	2

The maximum surface temperature T in relation to the switch type, the connection type and the maximum ambient temperature for the assembly type LDNA for category 1D or 2D is listed in above table and based on a layer of dust thickness of maximum 200mm.

Attention: No change in part or vendor allowed without prior approval of DEKRA